

You have just purchased the complete pack which is designed to allow all mechanics experiments in 2D marking.

1 Composition

This complete product is designed by Jeulin making experiments in Mechanics safer and easier to perform.

This pack comprises:

- 1 table
- 1 set of 50 sheets
- 2 pucks
- 2 ink cartridges (1 black and 1 red)
- 2 batteries, 9 V – 300 mAh
- 1 power transformer block 12 V-500 mA and 'Y' cable to connect 2 pucks
- 2 humidifier bases
- 1 remote control
- 1 edge marking accessory
- 1 accessory to find the centre of gravity of 2 linked pucks
- 1 inclining accessory
- 1 rotation accessory
- 1 set of 2 foam bands for elastic collisions
- 1 set of 2 Velcro bands for inelastic collisions
- 2 additional weights, each approx. 200 g
- 1 calibrated spring launcher
- 1 accelerometry experiment kit comprising:
 - o 1 weight holder
 - o 3 weights, each 5 cN
 - o 1 inelastic thread already connected to the weight holder and fastening for puck.
- 1 airtight box to store your inkjet cartridges during the summer holidays.

1.1 Table

The table, lightweight and very flat, comprises:

- 2 brackets to attach your accessories: launcher and accelerometer
- 3 screws to adjust to horizontal
- 1 ring

Supplied with a pack of 50 sheets of A1 paper.

Table dimensions: 935 x 750 mm.

Important :

Before using your product for the first time and in order to ensure follow-up over time, please note the date of implementation, lab assignment on the stapled label to this booklet and paste it into this table location :

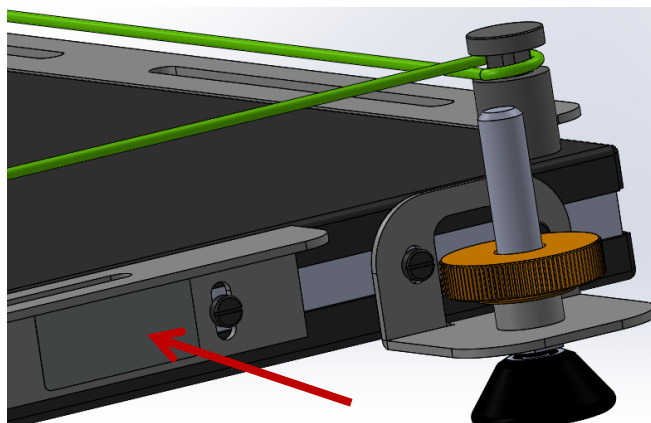

1.2 Pucks

On receipt, the ink cartridges and batteries supplied are not fitted into the pucks.

The user should fit these items in the pucks as described below.

1/ Open the puck (2 screws)

2/ Open the airtight cover (4 screws) enclosing the ink cartridge and pump

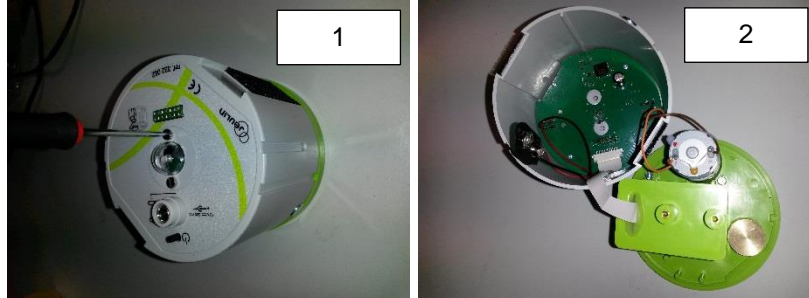

Warning: the removal of the hood should be no sudden move to avoid breaking flouder

3/ Fit the ink cartridge (see picture): take care to clip it correctly into its seat

4/ Connect the battery and place it in its housing (between the 3 ridges)

5/ Close the airtight cover



Caution: Position the seal in its notch before closing the cover to maintain a perfect seal. In the case where the seal would be poorly positioned, the air cushion would not be strong enough to ensure satisfactory lift.



6/ Close the cover of the puck, being careful not to twist the ribbon cable of the ink cartridge. Use the guide notches to close up the puck.



Power supply to the puck:

Supply power to the pucks using the power transformer block + 'Y' cable.

A LED on the top of the puck shows its charge status.

- LED off = puck charged
- LED orange = puck charging
- LED red = puck discharged

For video capture:

A central two-colour LED on the puck makes it very easy to locate the puck during video experiments.

It is possible to change the color of this LED by holding down the button for a long time when starting the puck.

1.3 Humidifier base

2 humidifier bases are supplied to protect the ink cartridges fitted in the pucks.



Puck on humidifier base.



After each use, it is **ESSENTIAL** that the puck is put back on the base. This avoids the ink cartridge drying out.

The sponge included in the base must be kept damp.

It is important not to touch the printing head unless it is dry.

If it is dry, delicately pass isopropyl alcohol over the printing head using a cotton bud.

If marking produces 2 lines from one puck, then the printing head is damaged. The ink cartridge must be changed.

1.4 Remote control



Remote control for inkjet pucks

The time gap between two successive marks is always constant to allow speed variations to be observed from the variation in distance.

A display indicates this Δt .

This remote control has 3 buttons.

The central button turns the remote control on. Hold the button down to mark the trajectory of the puck at the indicated Δt , all the time it is moving.

The '+' and '-' buttons are used to vary the Δt from 20 to 100 ms in 5 ms steps.

The remote control turns off automatically after 5 minutes.

1.5 Markings outside the puck

1.5.1 Markings at the edge of the puck



Edge marking accessory

The edge marking accessory consists (fig. 3 - left) in an ink cartridge holder with marking synchronised with the puck. The second component is a counterweight to balance the puck.

The steps for fitting this accessory are described below:

1/ Put an ink cartridge (ordered separately or removed from one of your pucks) in the ink cartridge holder



2/ Fix and connect the cartridge holder to the puck



3/ Place the counterweight on the puck opposite the ink cartridge holder



Your puck is ready to make synchronised markings at its centre and at its edge.

1.5.2 Marking at the centre of two linked pucks

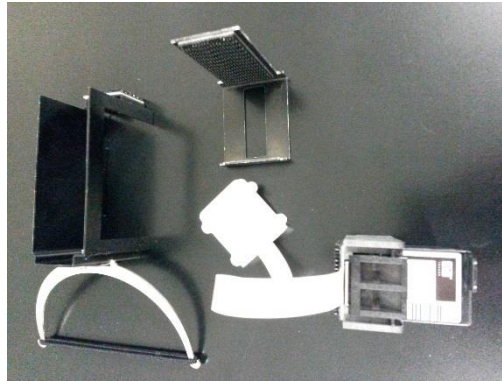

1 Centre of gravity marking set (the ink cartridge should be removed from one of the pucks).

Step 1: Place your ink cartridge in the cartridge holder.



Step 2: pass the connector through the window of the L-bracket with Velcro, then velcro the cartridge holder in the L-bracket.



Step 3: Use Velcro to fix the rectangle to a puck, then attach the puck diametrically opposite using a ring and the elastic supplied.



Inkjet puck – Complete pack

Step 4: Slide the assembly with ink cartridge into the rectangle.



Step 5: Connect this marking accessory over the top of the puck containing an ink cartridge (see picture below).

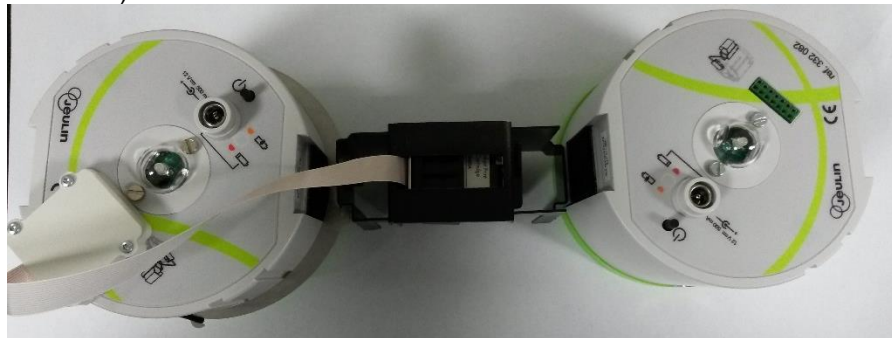

Precautions: Be careful to place the pucks symmetrically relative to the central point of the assembly of two linked pucks. See picture above.

1.6 Inclining accessory



Inclining accessory

The inclining accessory looks like stairs; each step inclines the table by 0.5°.

To incline the table suitably, this accessory must be placed under the foot of the table as shown below.

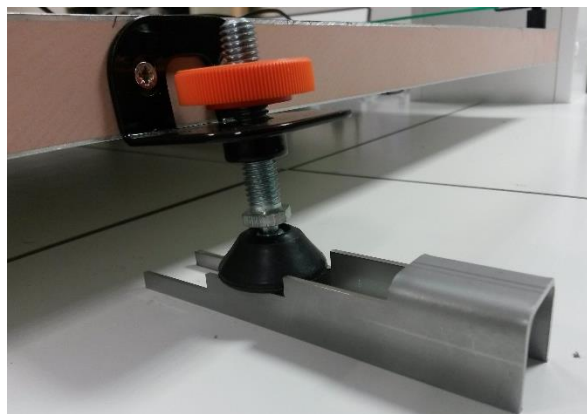

Inclining accessory to be placed under the foot of the table [side where there is only one foot].

1.7 Launcher accessory

The launcher supplied consists of a spring of known and controlled resistance. Several compressions are possible. The puck can therefore be launched with different known forces.

The resistance of the spring is: 200 N.m^{-1}

The different possible forces are: 4 N; 5 N; 6 N; 7 N; 8 N and 9 N.

The launcher must be fixed to the table using the locking screws supplied.

To launch it as a parabola, fix the launcher with only one screw and point it along your chosen axis. See picture below.

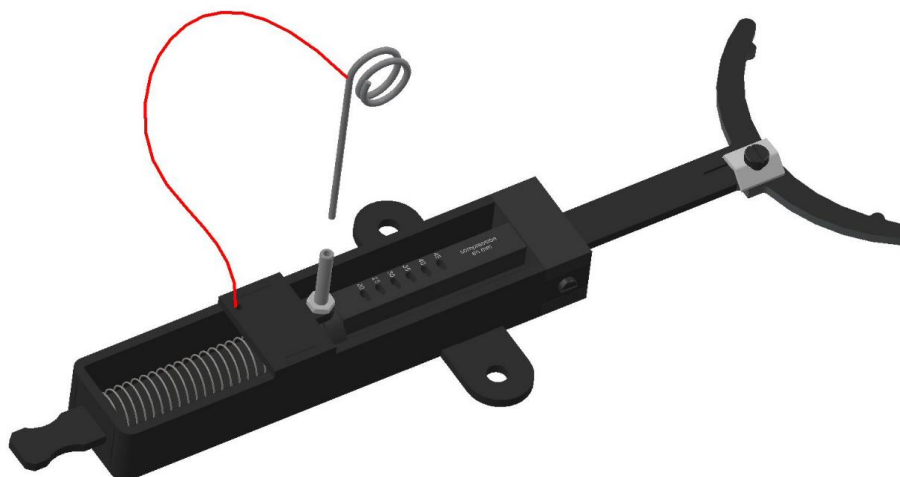

Calibrated launcher accessory

This launcher has a silk-screen printed scale showing the compression in mm. It is up to the students to use their knowledge to find the force exerted by a spring.

1.8 Rotation accessory

A metal block with a pin on the top is supplied for rotation movements.

Place the block on the table, use the non-stretch nylon thread supplied and tie the puck as shown in the photo below.



Inkjet puck tied to the pin for circular movement

It may be practical to make up a template for known thread lengths to make tying the thread easier.

For circular then rectilinear movement, release the thread from the pin during circular motion.

1.9 Collision accessories

1.9.1 Accessories for soft collisions

Two pieces of Velcro are supplied to link the two puck together after collision.

While holding the slightly projecting base of the puck: wind the loop side of the Velcro for one puck and then do the same with the hook side on the second puck. You need to go round several times (3 turns) to ensure this accessory works properly.

For a soft (or inelastic) collision that is easy to analyse: secure one puck in the centre of the table and aim at it with a second puck (Make sure the Velcro is fitted to the pucks). The first puck will remain stationary and the speed of the second puck will be the speed of the first puck before the collision.

1.9.2 Accessories for hard collisions

Two foam bands or known compression are used to cause hard (or elastic) collisions.

Wrap the foam bands around each puck and check that when 2 pucks collide there is no loss of energy.

1.10 Extra weights

2 metal weights (rings) are provided
The weights are placed over the pucks.
Each weight weighs $m_{\text{weight}} = 0.5 \times m_{\text{puck}}$.

Weight ring (supplied as set of 2)



For accurate calculations, we recommend considering the weights of both the pucks and the weights.

1.11 Accelerometry accessory

Composition:

- 1 offset pulley with foam protection
- 1 weight holder, 0.05 N to connect to the puck
- 3 weights, each 0.05 N

Accelerometry accessory



To fit this accessory correctly, follow the steps below:

- Fix the pulley + foam assembly to one of the table brackets

*Offset pulley fitted to one of the table brackets supplied
(view from above)*



Inkjet puck – Complete pack

- Fix the weight holder to the puck using the tab with Velcro.



Tab with Velcro to be fixed to puck

- Pass the non-stretch nylon thread supplied into the guide of the offset pulley and place the thread on the pulley wheel.



Accelerometer accessory

The weight holder, like each weight, has a mass such that the weight delivers a force of 0.050 N.

These items are marked in Newton to make students think about the unit used. The teacher is free to use this marking or to provide the masses of the weights and weight holder.