

# Wireless Weather Sensor with GPS

PS-3209

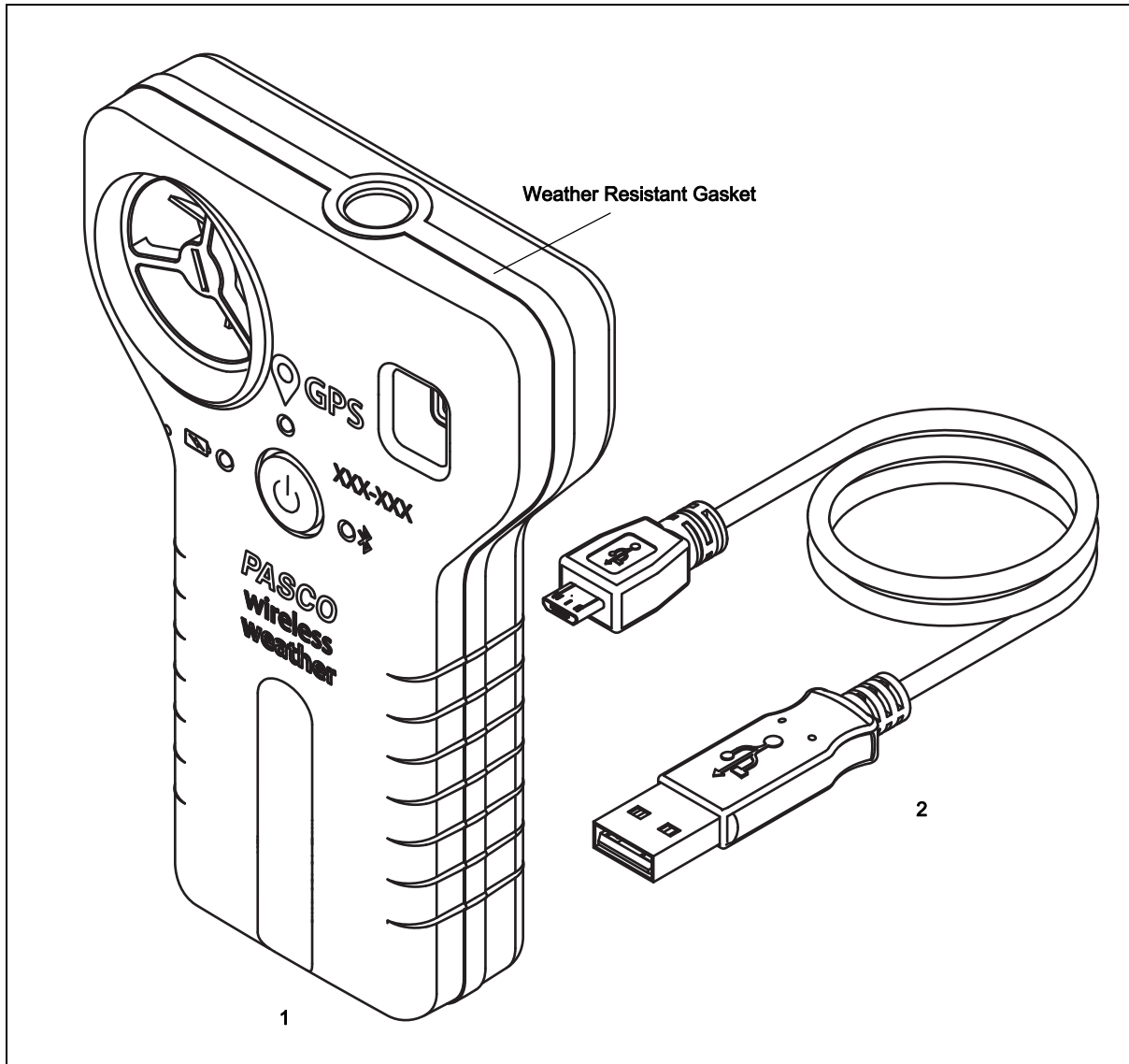

Included Equipment	Item	Included Equipment	Item
Wireless Weather Sensor with GPS	1	USB-to-Micro-USB Cable	2

# Introduction

This Wireless Weather Sensor with GPS is a versatile instrument with multiple sensors, including a global positioning system (GPS) module. It is durable and weather-resistant (IP-64) and can connect wirelessly via Bluetooth to a computing device such as a tablet or computer using PASCO data collection software (see [www.pasco.com](http://www.pasco.com)). The software supports data logging when the instrument is not connected to a computing device. The Wireless Weather Sensor has a rechargeable battery pack.

The sensor measures wind speed, wind direction, barometric pressure, humidity, ambient temperature, light level, UV index, and magnetic heading. The GPS module reports latitude, longitude, altitude, speed, and satellite count. The software can calculate dew point, wind direction, wind chill, absolute humidity, and heat stress index.

## Features

The included one-meter long USB cable has a “Micro-B” type plug at one end and a Type A plug at the other end.

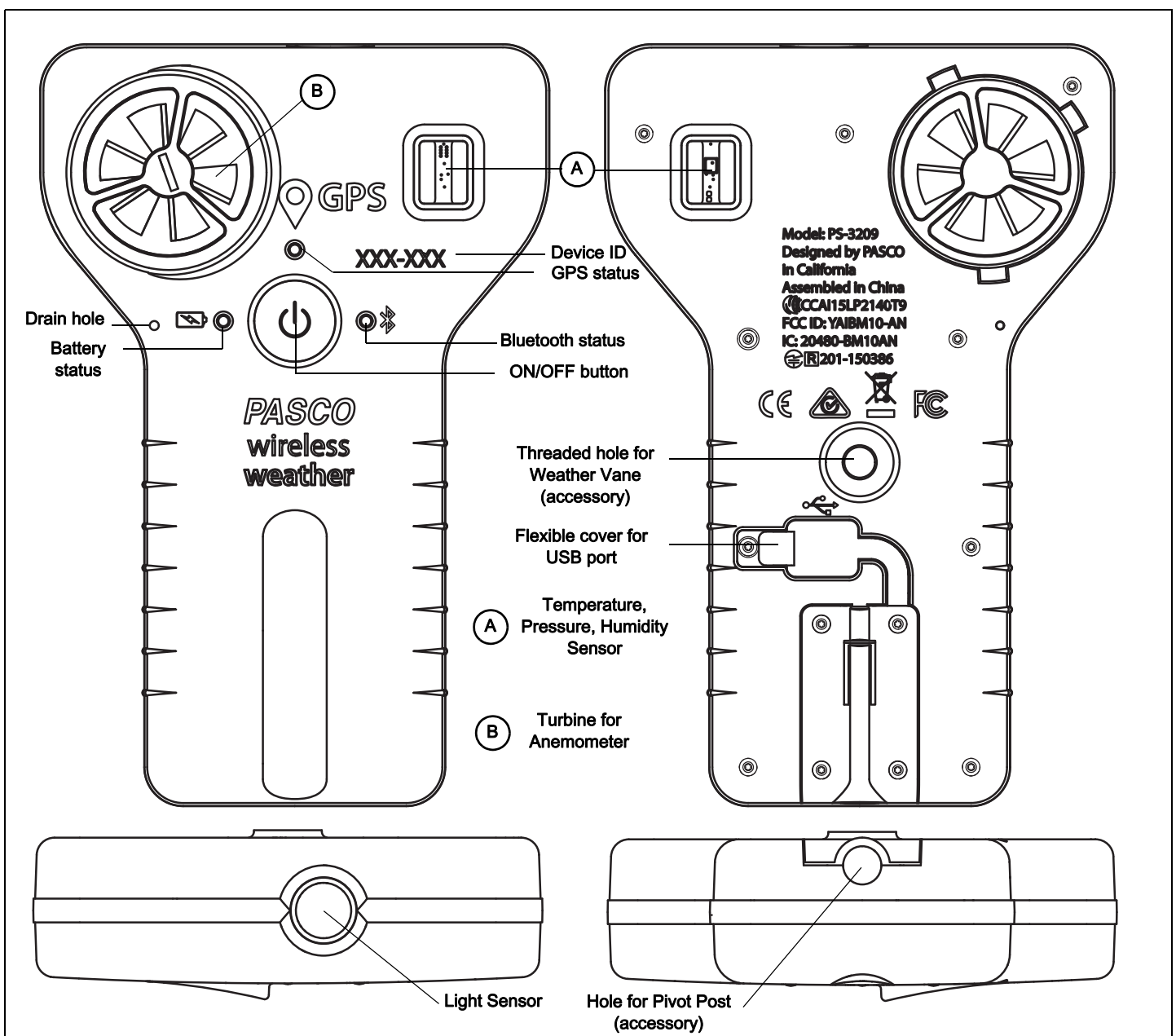

## Recommended Items

- Weather Vane Accessory (PS-3553)

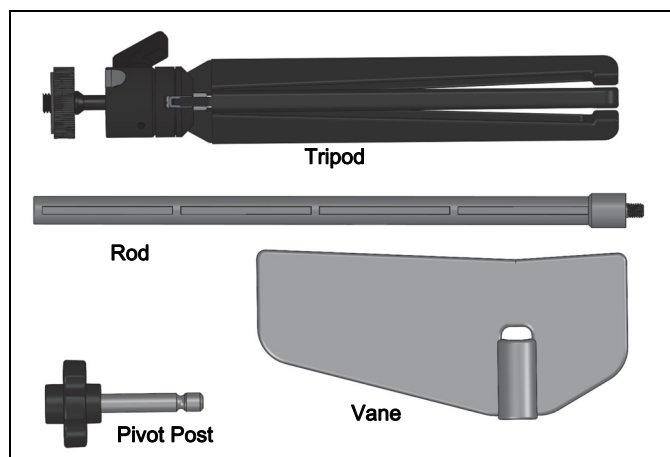

- PASCO data collection software (see [www.pasco.com/downloads](http://www.pasco.com/downloads))

## Operation

### Charge the Battery

- Connect the USB Cable:** Gently pull the tab of the flexible cover to the right to gain access to the USB port.

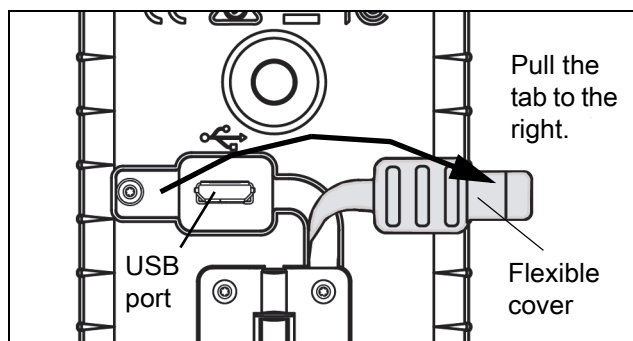

- Use the Micro USB Cable to connect the micro USB port on the back of the Wireless Weather Sensor to a USB port on a USB charger (or a computing device). Charging begins automatically. The battery status LED shines yellow while the unit is charging, and will shine green when the battery is charged. The charger circuit inside the Weather Sensor turns itself off when the unit is fully charged. The battery is partially charged at the factory. Initial charging time may be three hours or longer. Press the flexible cover back in place after removing the USB cable.

### Turn on the Sensor

Press the ON/OFF button. All three status LEDs will shine momentarily. If the battery is charged, the Battery status LED will stop shining. The GPS status and the Bluetooth status LEDs will continue to blink red. This indicates that the device is ready to connect to GPS satellites and connect wirelessly via Bluetooth to a computing device such as a computer or tablet.

To turn off the sensor, press and HOLD the ON/OFF button until the Battery status LED shines red momentarily and the other status LEDs stop shining.

### Software Help

NOTE: See the SPARKvue Help or PASCO Capstone Help for information about collecting, displaying, and analyzing data.

- In SPARKvue, select the HELP button in any screen including the Home Screen.
- In PASCO Capstone, select PASCO Capstone Help from the Help menu, or press F1.

### Connect the Sensor Wirelessly

Start the PASCO data collection software (such as PASCO Capstone or SPARKvue).

**PASCO Capstone:** Select "Hardware Setup" in the Tools palette. When the software detects the Wireless Weather Sensor, the Bluetooth status LED on the sensor blinks green. In the Hardware Setup window, select the sensor that has a six-digit Device ID that matches the Device ID on the sensor itself. After searching, the software should display the Weather Sensor, GPS Position Sensor, and Light Sensor in Hardware Setup.

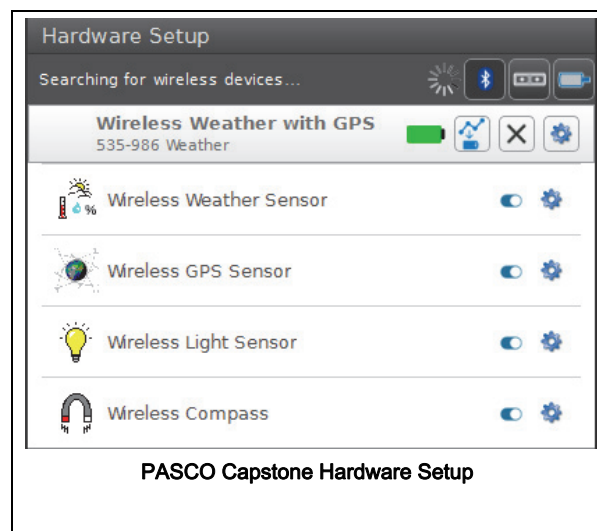

SPARKvue: In the Home screen, select the “Bluetooth” icon at the top of the screen. The Wireless Sensors window opens.



Select the “Available Device” that has the same six-digit Device ID as the one on the sensor. Select “Done”.

The SPARKvue Sensors window opens with a list of all the available measurements possible with the sensor.

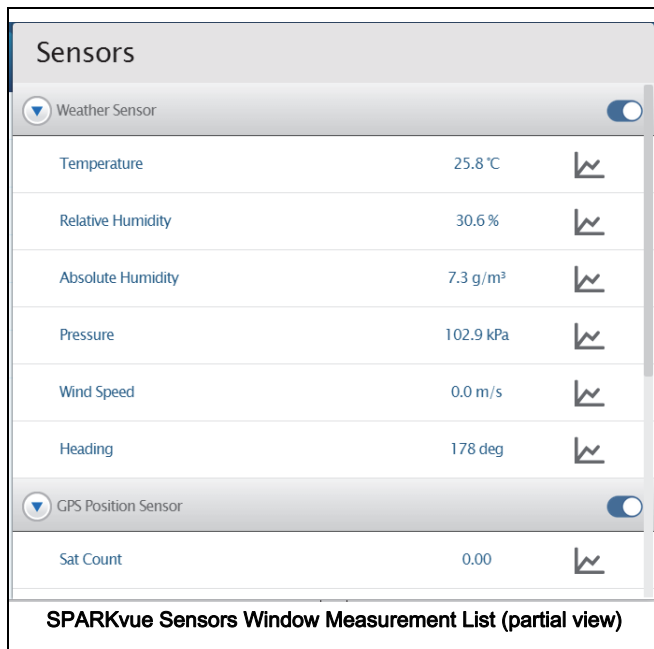

Select a measurement to automatically open a Graph display or pick a QuickStart template.

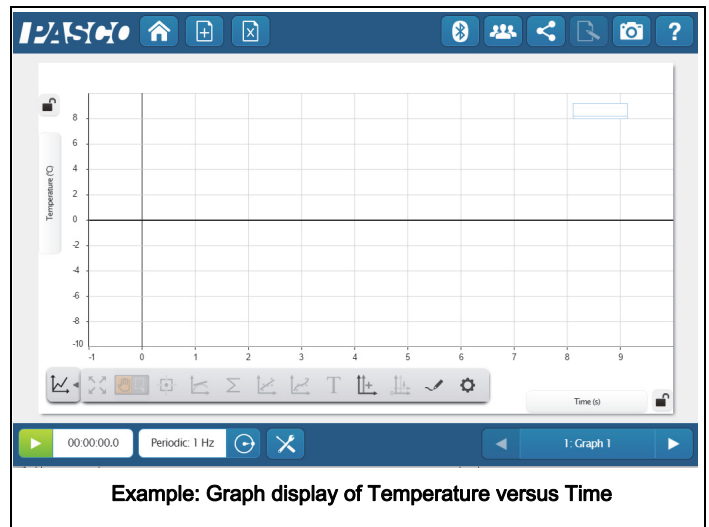

### Status LED Information

The Bluetooth, GPS, and the Battery Status LEDs operate as follows depending on the type of connection:

#### For a connection to the USB Charger or a USB Port

Bluetooth/GPS	Status	Battery	Status
Red blink	Ready to pair	Yellow ON	Charging
Green blink	Connected	Green ON	Charged

#### For a wireless Bluetooth connection

Bluetooth/GPS	Status	Battery	Status
Red blink	Ready to pair	Red blink	Low power
Green blink	Connected		

### Using the Weather Sensor

The Wireless Weather Sensor is weather resistant, so it is useful for outdoor measurements. Remember that the sensor is weather resistant but not waterproof.

Consider using the PS-3553 Weather Vane Accessory when measuring weather conditions including wind speed and direction.



Wireless Weather Sensor and Weather Vane Accessory

## Measurement Tips

### Equilibration Time

After a rapid change in temperature or humidity, the sensor may take several seconds to come to equilibrium with the environment. Observe the measurements and wait for them to stabilize.

### Alignment with Wind

Hold the sensor so that wind blows straight into the front of the anemometer.

### Shade

The sensor, especially the temperature and humidity transducers, must be out of direct sunlight to make accurate measurements.

### Moisture

Protect the sensor from liquid water. The sensor is rugged and weather-resistant, but not waterproof.

# Wireless Weather Sensor

## Primary Measurements

The primary measurements are wind speed, temperature, relative humidity, and barometric pressure.

### Wind Speed

The sensor determines Wind Speed from the rate of rotation of the anemometer (wind turbine). It assumes that air is flowing straight into the turbine. Wind speed must be at least 0.5 m/s to be measured accurately. Wind speed is measured in units of m/s, cm/s, mm/min, km/h, mph (miles per hour), knots, and ft/s (feet per second).

**CAUTION:** Do not try to measure high-speed wind such as from leaf-blowers or severe storms.

### Temperature

Temperature is measured by the thermistor temperature transducer. To work accurately, the transducer must be in shade. Temperature is measured on the Celsius, Fahrenheit, and Kelvin scales.

### Relative Humidity

Relative humidity is measured by the humidity transducer. To work accurately, the transducer must be in shade and at air temperature. Relative humidity is reported as a percentage representing the ratio of the partial pressure of water vapor to the saturated vapor pressure. Relative humidity is reported as “%”.

### Barometric Pressure

Barometric Pressure is measured by a pressure transducer in the sensor’s “window”. The reported Barometric Pressure is the actual air pressure, not sea-level corrected pressure. Barometric Pressure is measured in units of kPa (default), psi, N/m<sup>2</sup>, atm, torr, hPa, inHg, mmHg, mbar, Pa, and inH<sub>2</sub>O

## Secondary Measurements

Each secondary measurement is a calculation based on one or more of the primary measurements.

### Absolute Humidity

Absolute Humidity (or water vapor density) is a measure of the mass of water vapor present in a given volume. It

is reported in units of  $\text{g/m}^3$ . The sensor calculates Absolute Humidity with the formula:

$$\text{Absolute Humidity} = \frac{13.24 \times \text{RH}}{T + 273.15} \times \exp\left(\frac{17.42T}{T + 239.7}\right)$$

where RH is Relative Humidity (as a percentage), and T is Temperature in  $^{\circ}\text{C}$ .

### Dew Point

Dew Point is the temperature to which air must be cooled at constant pressure for water vapor to condense. Dew Point is reported as a temperature on the Celsius and Fahrenheit scales. The sensor calculates Dew Point (in  $^{\circ}\text{C}$ ) with the formula:

$$\text{Dew Point} = \frac{-430.22 + 237.7 \times \ln\left(\frac{\text{SatVP} \times \text{RH}}{100}\right)}{-\ln\left(\frac{\text{SatVP} \times \text{RH}}{100}\right) + 19.08}$$

In this formula,  $\text{SatVP} = 6.11 \times 10^{7.75 \times T / (237.7 + T)}$  is the saturation water vapor pressure, RH is Relative Humidity (as a percentage), and T is Temperature in  $^{\circ}\text{C}$ .

### Wind Chill

Wind Chill (or Wind Chill Index) indicates a combined effect of temperature and wind speed. It is reported as an apparent temperature on the Celsius and Fahrenheit scales. The sensor calculates Wind Chill (in  $^{\circ}\text{F}$ ) using the formula:

$$\text{Wind Chill } (^{\circ}\text{F}) = 35.74 + 0.6215T - 35.75V^{0.16} + 0.4275T^{0.16}$$

where T is air temperature (in  $^{\circ}\text{F}$ ) and V is wind speed (in miles per hour).

Wind Chill is defined for temperatures at or below  $50^{\circ}\text{F}$  and wind speed above 3 miles per hour; outside of those limits, the sensor reports a value equal to Air Temperature.

### Heat Stress Index (Humidex)

Heat Stress Index (Humidex) indicates a combined effect of temperature and humidity. It is reported as an apparent temperature on the Celsius and Fahrenheit scales. The sensor calculates Humidex (in  $^{\circ}\text{C}$ ) using the formula:

$$A(^{\circ}\text{C}) = \frac{(-1.3 + 0.92T)}{2.2e}$$

where T is ambient air temperature in  $^{\circ}\text{C}$ , and e is the water vapor pressure in kPa.

### Sea-level Corrected Pressure

A typical weather station does not report the actual measured barometric pressure. Rather, it reports a "sea-level corrected" value. Use this formula to calculate the sea-level corrected pressure (in mbar):

$$[\text{Barometric Pressure (mbar)}] + 1013 * (1 - \exp(-h/7000))$$

where h is the sensor's elevation in m. To have this calculation done automatically, enter it in the calculator of the data collection software.

## Wireless GPS Sensor

The Wireless GPS Sensor uses signals received from the Global Positioning System (GPS) to determine its latitude, longitude, altitude and horizontal velocity anywhere on earth. Use it alone or in conjunction with other sensors for outdoor experiments in environmental science, physics, and other subjects.

Data from the Wireless GPS Sensor is relayed by Bluetooth to the PASCO data collection software on a computing device such as a computer or tablet.

### Theory of Operation

To determine its position, the sensor must receive data from at least three satellites. When the sensor is first powered on, it searches the sky for available satellites. This process typically takes between 30 seconds and 2 minutes. Once satellites have been identified, the sensor actively tracks them and acquires new satellites as they come into view.

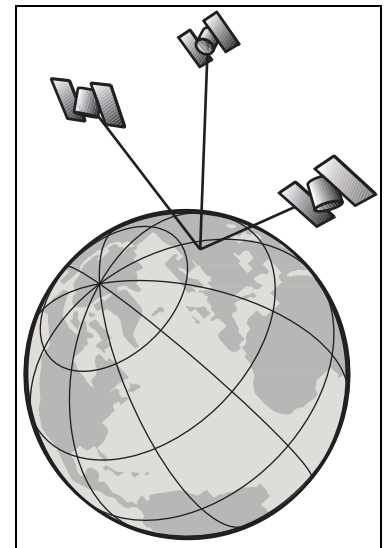

The Wireless GPS Sensor performs best outdoors with a clear view of the sky.

## Sensor Set-up

### Orientation and Positioning

It is important to orient the sensor properly to receive signals from satellites overhead, especially during initial search mode (when the GPS status LED is blinking). The antenna detects signals through the top side of the sensor. The antenna is located above the rectangular window that houses the temperature, pressure, and humidity sensing elements. Hold the sensor with the top side up and approximately horizontal and facing the sky. Do not cover the antenna area.

### Modes

The color of the GPS status LED indicates whether or not the sensor is ready to make measurements. At initial power on, the sensor enters “search mode”, in which it searches the sky for available satellites. Initial search mode typically lasts between 30 seconds and 2 minutes. During “search mode”, the LED blinks red.

When the sensor is actively tracking three or more satellites, the LED blinks green.

If the Wireless GPS Sensor is turned off in the data collection software, or there is a hardware problem, the GPS status LED does not shine.

If the sensor cannot track at least three satellites, it enters GPS “lost mode”. In this mode it continues to report its most recent position measurements. Use this “stale” data with caution; it is incorrect if the sensor has moved since its last valid measurement. In GPS lost mode, the status LED blinks red and the sensor searches for available satellites again.

## Wireless Light Sensor

The Wireless Light Sensor measures illuminance (measured in lux or lumen per square meter) and ultra-violet index (UVI). For greatest accuracy, make sure that the white disk on the top of the sensor is clean and dry.

## Wireless Compass

The Wireless Compass measures magnetic heading in degrees and radians.

### Wind Direction (Magnetic)

When used with the PS-3553 Wireless Weather Accessories, the Wireless Compass gives wind direction.

### Wind Direction (True)

The Wireless GPS Sensor’s coordinates combined with the declination/variation for the sensor’s location produces a calculated corrected/true wind direction.

## Battery Life

### Battery Usage

Battery life is very important to making the Wireless Weather Sensor simple and always ready to use, so all of the PASCO wireless products are designed for long battery life. For example, the Weather Sensor turns itself off after a brief time of inactivity to conserve battery life.

The battery life between charges for the Weather Sensor ranges from two days to more than a week depending on active sensors and sample rate.

If the battery status LED blinks red, connect the Weather Source to the USB Charger or to a USB port.

### Maximizing Battery Life

One of the factors that affects battery life is the storage temperature. Therefore, avoid storing the Weather Source in very cold or very hot environments.

If the battery will not hold a charge, contact PASCO Technical Support.

## Replacement Items

The Wireless Weather Sensor with GPS wind turbine can be replaced with the PS-9879 Impeller Replacement-Anemometer. Check with Technical Support regarding possible replacement items.

## Technical Support

For assistance with any PASCO product, contact PASCO at:

**Address:** PASCO scientific  
10101 Foothills Blvd.  
Roseville, CA 95747-7100

**Phone:** 916-462-8384 (worldwide)  
800-772-8700 (U.S)

**Email:** techsupp@pasco.com

**Web:** www.pasco.com/support

### Limited Warranty

For a description of the product warranty, see the PASCO catalog.

### Copyright

This PASCO scientific reference guide is copyrighted with all rights reserved. Permission is granted to non-profit educational institutions for reproduction of any part of this manual, providing the reproductions are used only in their laboratories and classrooms, and are not sold for profit. Reproduction under any other circumstances, without the written consent of PASCO scientific, is prohibited. Rev: 12/17

### Trademarks

PASCO, PASCO scientific, PASCO Capstone, PASPORT and SPARKvue are trademarks or registered trademarks of PASCO scientific, in the United States and/or in other countries. All other brands, products, or service names are or may be trademarks or service marks of, and are used to identify, products or services of, their respective owners. For more information visit [www.pasco.com/legal](http://www.pasco.com/legal).

### Product End of Life Disposal Instructions:

This electronic product is subject to disposal and recycling regulations that vary by country and region. It is your responsibility to recycle your electronic equipment per your local environmental laws and regulations to ensure that it will be recycled in a manner that protects human health and the environment. To find out where you can drop off your waste equipment for recycling, please contact your local waste recycle/disposal service, or the place where you purchased the product.

The European Union WEEE (Waste Electronic and Electrical Equipment) symbol (to the right) and on the product or its packaging indicates that this product must not be disposed of in a standard waste container.



### Battery Disposal Instructions:

Batteries contain chemicals that, if released, may affect the environment and human health. Batteries should be collected separately for recycling, and recycled at a local hazardous material disposal location adhering to your country and local government regulations. To find out where you can drop off your waste battery for recycling, please contact your local waste disposal service, or the product representative.

The Lithium Polymer (Li-Poly) rechargeable battery used in this product is marked with the International symbols to indicate the need for the separate collection and recycling of batteries.



Li-Poly

